

THIS DRAWING IS UNPUBLISHED. RELEASED FOR PUBLICATION .19
 © COPYRIGHT 19 BY AMP INCORPORATED. ALL RIGHTS RESERVED.

LOC	DIST	REVISIONS			
P	LTR	DESCRIPTION	DATE	DWN	APVD
AF	50	J	REV PER OG3A-0253-01	10APR01	JR DD

- 1 CONTINUOUS STRIP ON REELS.
- 2 FOREIGN PRODUCTION ONLY.
- 3 0.002032 [.000080] MIN TIN PLATE.
- 4 0.000381 [.000015] MIN GOLD PLATE OVER
0.000762 [.000030] MIN NICKEL UNDERPLATE.
- 5 0.003810 [.000150] MIN NICKEL PLATE.
- 6 WIRE BARREL TO ACCEPT #22-#18 AWG STRANDED LEAD WIRE.
- 7 INSULATION BARREL ACCEPTS 2.16-3.18 [.085-.125] DIA INSULATION.

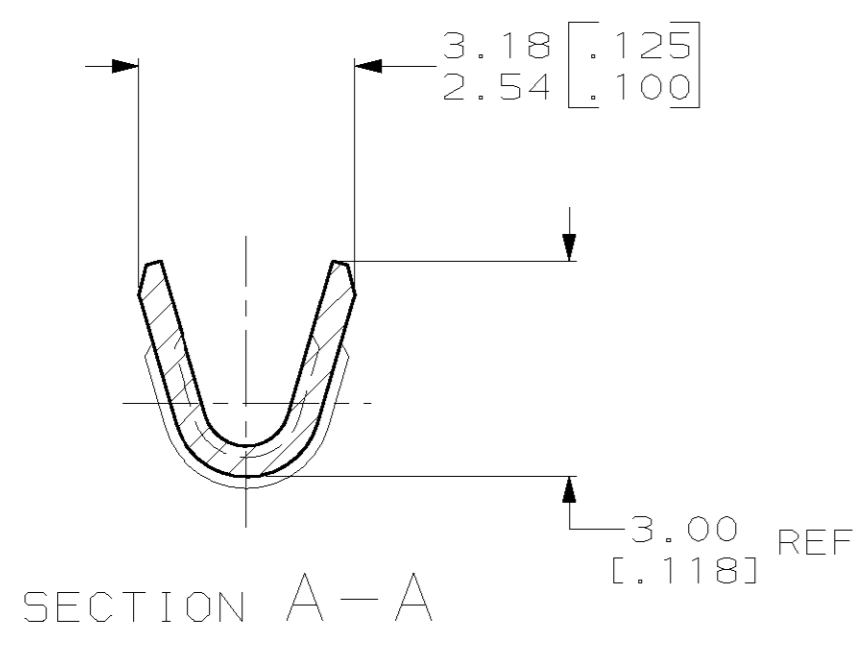
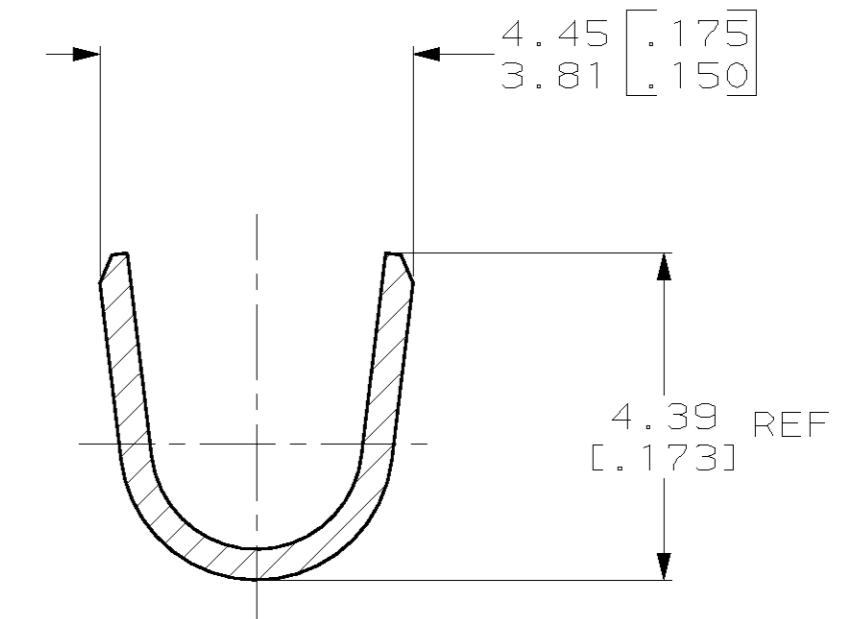
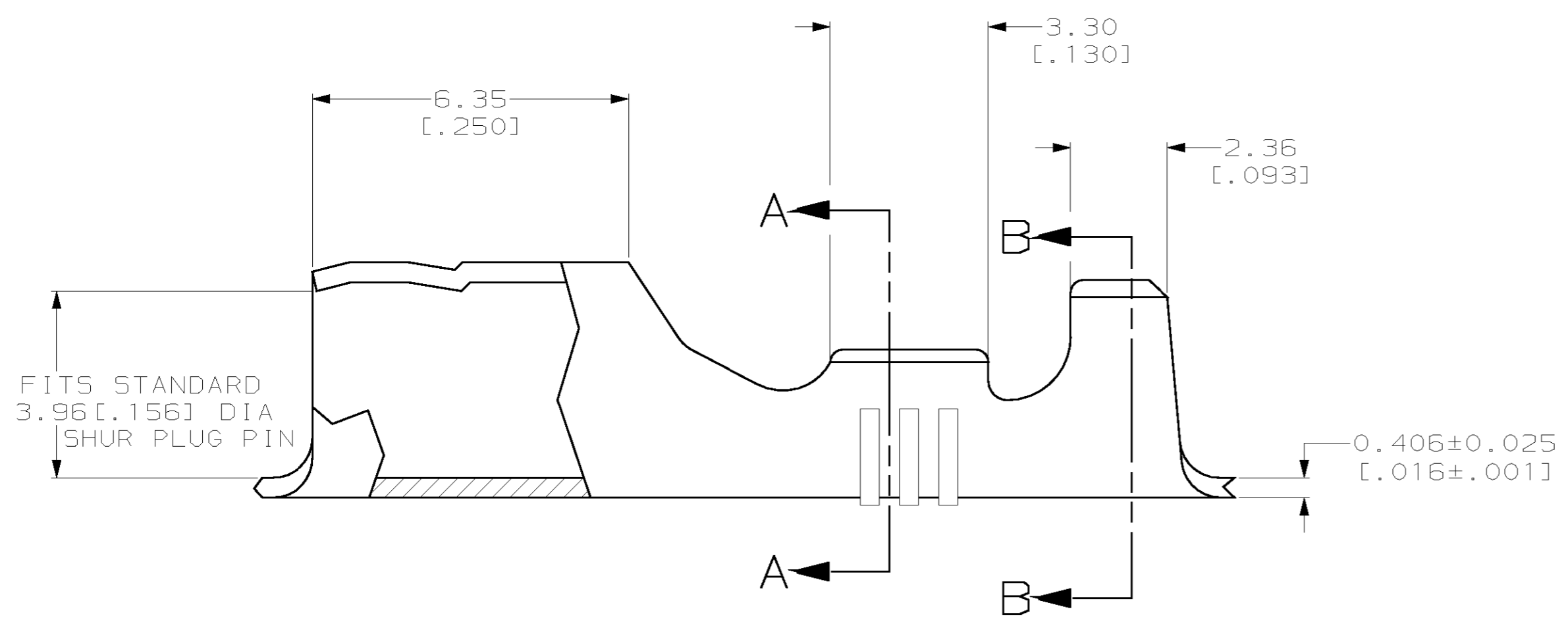
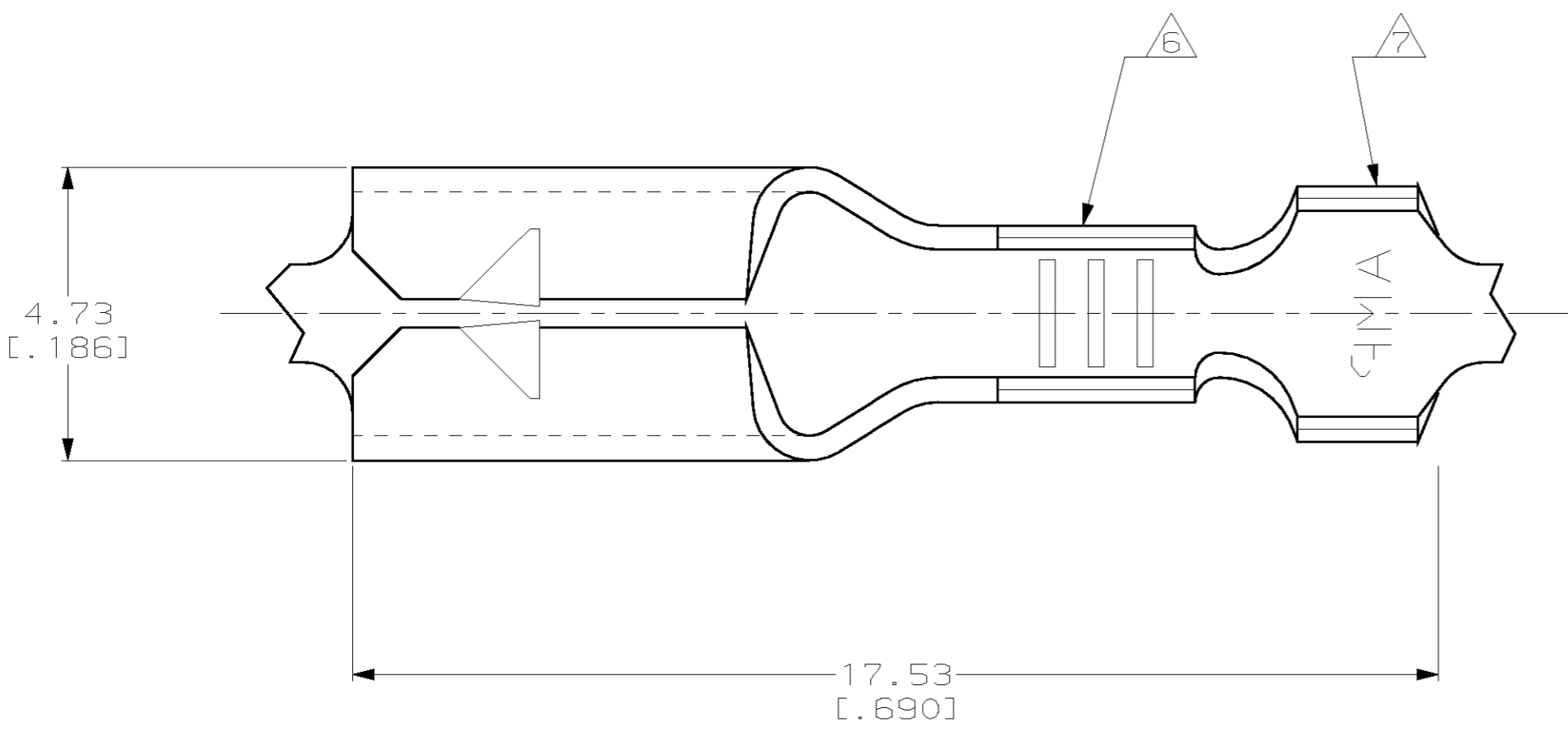

FINISH	PART NUMBER
OBSOLETE	42581-4
OBSOLETE	42581-3
OBSOLETE	42581-2
OBSOLETE	42581-1

THIS DRAWING IS A CONTROLLED DOCUMENT.		DWN MICHAEL S. FEHER 21JUL1999	AMP Incorporated Harrisburg, PA 17105-3608	
DIMENSIONS: mm [INCHES]		CHK DON DECKER 23JUL1999	NAME RECEPTACLE, SHUR PLUG, 3.96 [.156] DIA	
TOLERANCES UNLESS OTHERWISE SPECIFIED: 0 PLC ±- 1 PLC ±- 2 PLC ±0.25 [.010] 3 PLC ±- 4 PLC ±- ANGLES ±- FINISH SEE TABLE		APVD DON DECKER 23JUL1999	DRAWING NO A2 00779 C- 42581	
MATERIAL 4M BRASS	WEIGHT -	APPLICATION SPEC -	SIZE A2	RESTRICTED TO -
CUSTOMER DRAWING		SCALE 5:1	SHEET 1 OF 1	REV J